

# Step Down Converter with Bypass Mode for Ultra Low Power Wireless Applications

Check for Samples: [TPS62730](#)

## FEATURES

- Input Voltage Range  $V_{IN}$  from 1.9V to 3.9V
- Typ. 30nA Ultra Low Power Bypass Mode
- Typ. 25  $\mu$ A DC/DC Quiescent Current
- Internal Feedback Divider Disconnect
- Typ. 2.1 $\Omega$  Bypass Switch between  $V_{IN}$  and  $V_{OUT}$
- Automatic Transition from DC/DC to Bypass Mode
- Up To 3MHz switch frequency
- Up to 95% DC/DC Efficiency
- Open Drain Status Output STAT
- Output Peak Current up to 100mA
- Fixed Output Voltage 2.1V
- Small External Output Filter Components 2.2 $\mu$ H/ 2.2 $\mu$ F
- Optimized For Low Output Ripple Voltage
- Small 1  $\times$  1.5  $\times$  0.6mm<sup>3</sup> SON Package
- 12 mm<sup>2</sup> Minimum Solution Size

## APPLICATIONS

- CC2540 Bluetooth Low Energy System-On-Chip Solution
- Low Power Wireless Applications
- RF4CE, Metering

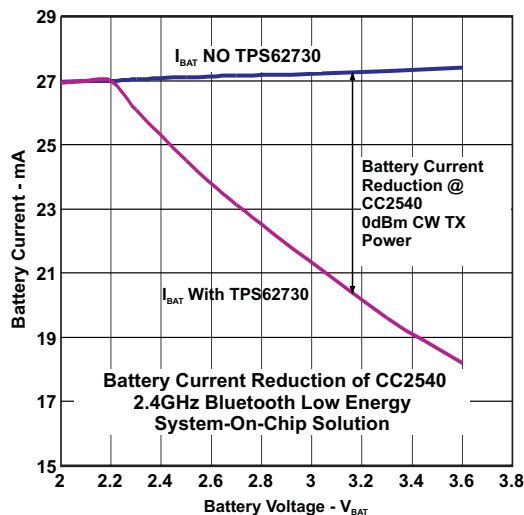

## DESCRIPTION

The TPS62730 is a high frequency synchronous step down DC-DC converter optimized for ultra low power wireless applications. The device is optimized to supply TI's Low Power Wireless sub 1GHz and 2.4GHz RF transceivers and System-On-Chip-solutions. The TPS62730 reduces the current consumption drawn from the battery during TX and RX mode by a high efficient step down voltage conversion. It provides up to 100mA output current and allows the use of tiny and low cost chip inductors and capacitors. With an input voltage range of 1.9V to 3.9V the device supports Li-primary battery chemistries such as Li-SOCI<sub>2</sub>, Li-SO<sub>2</sub>, Li-MnO<sub>2</sub> and also two cell alkaline batteries.

The TPS62730 features an Ultra Low Power bypass mode with typical 30nA current consumption to support sleep and low power modes of TI's CC2540 Bluetooth Low Energy and CC430 System-On-Chip solutions. In this bypass mode, the output capacitor of the DC/DC converter is connected via an integrated typ. 2.1 $\Omega$  Bypass switch to the battery.

In DC/DC operation mode the device provides a regulated output voltage of 2.1V to the system. With a switch frequency up to 3MHz, the TPS62730 features low output ripple voltage and low noise even with a small 2.2 $\mu$ F output capacitor. The automatic transition into bypass mode during DC/DC operation prevents an increase of output ripple voltage and noise once the DC/DC converter operates close to 100% duty cycle. The device automatically enters bypass mode once the battery voltage falls below the transition threshold  $V_{IT\_BYP}$ . The TPS62730 is available in a 1  $\times$  1.5mm<sup>2</sup> 6 pin QFN package.

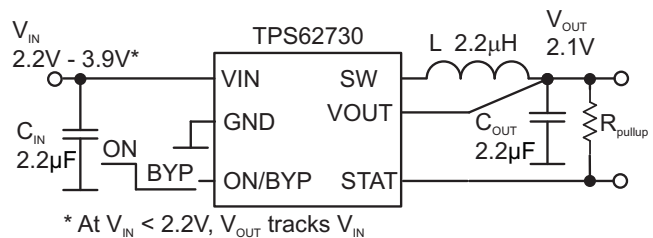

Please be aware that an important notice concerning availability, standard warranty, and use in critical applications of Texas Instruments semiconductor products and disclaimers thereto appears at the end of this data sheet.



These devices have limited built-in ESD protection. The leads should be shorted together or the device placed in conductive foam during storage or handling to prevent electrostatic damage to the MOS gates.

### ORDERING INFORMATION

T <sub>A</sub>	PART NUMBER <sup>(1)</sup>	OUTPUT VOLTAGE [V] <sup>(2)</sup>	Automatic Bypass Mode Transition Thresholds V <sub>IT BYP</sub>			ORDERING	PACKAGE MARKING
			V <sub>IT BYP</sub> [V] rising V <sub>IN</sub>	V <sub>IT BYP</sub> [V] falling V <sub>IN</sub>	V <sub>IT BYP</sub> [mV] hysteresis		
–40°C to 85°C	TPS62730	2.10	2.25	2.20	50	TPS62730DRY	RP
	TPS62731 <sup>(2)</sup>	2.05	2.2	2.15	50	TPS62731DRY	RQ
	TPS62732 <sup>(2)</sup>	1.90	2.10	2.05	50	TPS62732DRY	RR
	TPS62734 <sup>(2)</sup>	2.10	2.28	2.23	50	TPS62734DRY	SL
	TPS62735 <sup>(2)</sup>	2.10	2.33	2.23	100	TPS62735DRY	SM

- (1) The DRY package is available in tape on reel. Add R suffix to order quantities of 3000 parts per reel, T suffix for 250 parts per reel.  
 (2) Device status is product preview, contact TI for more details

### ABSOLUTE MAXIMUM RATINGS

over operating free-air temperature range (unless otherwise noted)<sup>(1)</sup>

		MIN	MAX	UNIT
Voltage range <sup>(2)</sup>	V <sub>IN</sub> , SW, V <sub>OUT</sub>	–0.3	4.2	V
	ON/BYP, STAT	–0.3	V <sub>IN</sub> +0.3, ≤4.2	V
Temperature range	Operating junction temperature, T <sub>J</sub>	–40	125	°C
	Storage, T <sub>stg</sub>	–65	150	°C
ESD rating <sup>(3)</sup>	Human Body Model - (HBM)		2	kV
	Machine Model (MM)		150	V
	Charge Device Model - (CDM)		1	kV

- (1) Stresses beyond those listed under *Absolute Maximum Ratings* may cause permanent damage to the device. These are stress ratings only, and functional operation of the device at these or any other conditions beyond those indicated under *Recommended Operating Conditions* is not implied. Exposure to absolute-maximum-rated conditions for extended periods may affect device reliability.  
 (2) All voltages are with respect to network ground terminal.  
 (3) ESD testing is performed according to the respective JEDEC standard.

### THERMAL INFORMATION

THERMAL METRIC <sup>(1)</sup>		DRY / 6 PINS	UNITS
θ <sub>JA</sub>	Junction-to-ambient thermal resistance	293.8	°C/W
θ <sub>JCtop</sub>	Junction-to-case (top) thermal resistance	165.1	
θ <sub>JB</sub>	Junction-to-board thermal resistance	160.8	
ψ <sub>JT</sub>	Junction-to-top characterization parameter	27.3	
ψ <sub>JB</sub>	Junction-to-board characterization parameter	159.6	
θ <sub>JCbot</sub>	Junction-to-case (bottom) thermal resistance	65.8	

- (1) For more information about traditional and new thermal metrics, see the *IC Package Thermal Metrics* application report, [SPRA953](#).

### RECOMMENDED OPERATING CONDITIONS

operating ambient temperature T<sub>A</sub> = –40 to 85°C (unless otherwise noted)

	MIN	NOM	MAX	UNIT
Supply voltage V <sub>IN</sub>	1.9		3.9	V
Effective inductance	1.5	2.2	3	μH
Effective output capacitance connected to V <sub>OUT</sub>	1.0		10	μF
Operating junction temperature range, T <sub>J</sub>	–40		125	°C
T <sub>A</sub> Operating free air temperature range	–40		85	

**ELECTRICAL CHARACTERISTICS**
 $V_{IN} = 3.0V$ ,  $V_{OUT} = 2.1V$ ,  $ON/BYP = V_{IN}$ ,  $T_A = -40^{\circ}C$  to  $85^{\circ}C$  typical values are at  $T_A = 25^{\circ}C$  (unless otherwise noted),  $C_{IN} = 2.2\mu F$ ,  $L = 2.2\mu H$ ,  $C_{OUT} = 2.2\mu F$ , see parameter measurement information

PARAMETER		TEST CONDITIONS	MIN	TYP	MAX	UNIT	
<b>SUPPLY</b>							
$V_{IN}$	Input voltage range		1.9		3.9	V	
$I_Q$	Operating quiescent current	ON/BYP = high, $I_{OUT} = 0mA$ . $V_{IN} = 3V$ device not switching		25	40	$\mu A$	
		$I_{OUT} = 0mA$ . device switching, $V_{IN} = 3.0V$ , $V_{OUT} = 2.1V$		34			
		ON/BYP = high, Bypass switch active, $V_{IN} =$ $V_{OUT} = 2.1V$		23			
$I_{SD}$	Shutdown current, Bypass Switch Activated	ON/BYP = GND, leakage current into $V_{IN}$ <sup>(1)</sup>		30	550	nA	
		ON/BYP = GND, leakage current into $V_{IN}$ , $T_A = 60^{\circ}C$ <sup>(1)</sup>		110			
<b>ON/BYP</b>							
$V_{IH\ TH}$	Threshold for detecting high ON/BYP	$1.9\ V \leq V_{IN} \leq 3.9V$ , rising edge		0.8	1	V	
$V_{IL\ TH}$	Threshold for detecting low ON/BYP	$1.9\ V \leq V_{IN} \leq 3.9V$ , falling edge	0.4	0.6		V	
$I_{IN}$	Input bias Current			0	50	nA	
<b>POWER SWITCH</b>							
$R_{DS(ON)}$	High side MOSFET on-resistance	$V_{IN} = 3.0V$		600		m $\Omega$	
	Low Side MOSFET on-resistance			350			
$I_{LIMF}$	Forward current limit MOSFET high-side	$V_{IN} = 3.0V$ , open loop		410		mA	
	Forward current limit MOSFET low side			410			
<b>BYPASS SWITCH</b>							
$R_{DS(ON)}$	Bypass Switch on-resistance	$V_{IN} = 2.1V$ , $I_{OUT} = 20mA$ , $T_{Jmax} = 85^{\circ}C$ $V_{IN} = 3V$		2.9	3.8	$\Omega$	
$V_{IT\ BYP}$	Automatic Bypass Switch Transition Threshold (Activation / Deactivation)	ON/BYP = high	TPS62730 (2.1V)	ON / falling $V_{IN}$	2.14	2.20	2.3
				OFF / rising $V_{IN}$	2.19	2.25	2.35
			TPS62731 (2.05V)	ON / falling $V_{IN}$	2.15		
				OFF / rising $V_{IN}$	2.20		
			TPS62732 (1.9V)	ON / falling $V_{IN}$	2.05		
				OFF / rising $V_{IN}$	2.10		
			TPS62734 (2.1V)	ON / falling $V_{IN}$	2.23		
				OFF / rising $V_{IN}$	2.28		
			TPS62735 (2.3V)	ON / falling $V_{IN}$	2.23		
				OFF / rising $V_{IN}$	2.33		
<b>STAT Status Output (Open Drain)</b>							
$V_{TSTAT}$	Threshold level for STAT OUTPUT in % from $V_{OUT}$	ON/BYP = high and regulator is ready, $V_{IN}$ falling		95		%	
		ON/BYP = high and regulator is ready, $V_{IN}$ rising		98			
$V_{OL}$	Output Low Voltage	Current into STAT pin $I = 500\mu A$ , $V_{IN} = 2.3V$		0.4		V	
$V_{OH}$	Output High Voltage	Open drain output, external pullup resistor			$V_{IN}$		
$I_{LKG}$	Leakage into STAT pin	ON/BYP = GND, $V_{IN} = V_{OUT} = 3V$		0	50	nA	
<b>REGULATOR</b>							
$t_{ONmin}$	Minimum ON time	$V_{IN} = 3.0V$ , $V_{OUT} = 2.1V$ , $I_{OUT} = 0\ mA$		180		ns	
$t_{OFFmin}$	Minimum OFF time	$V_{IN} = 2.3V$		50		ns	
$t_{Start}$	Regulator start up time from transition ON/BYP = high to STAT = low	$V_{IN} = 3.0V$ , $V_{OUT} = 3.0V$		50		$\mu s$	

(1) Shutdown current into VIN pin, includes internal leakage

# TPS62730

SLVSAC3–MAY 2011

www.ti.com

## ELECTRICAL CHARACTERISTICS (continued)

$V_{IN} = 3.0V$ ,  $V_{OUT} = 2.1V$ ,  $ON/BYP = V_{IN}$ ,  $T_A = -40^{\circ}C$  to  $85^{\circ}C$  typical values are at  $T_A = 25^{\circ}C$  (unless otherwise noted),  $C_{IN} = 2.2\mu F$ ,  $L = 2.2\mu H$ ,  $C_{OUT} = 2.2\mu F$ , see parameter measurement information

PARAMETER		TEST CONDITIONS		MIN	TYP	MAX	UNIT
<b>OUTPUT</b>							
$V_{REF}$	Internal Reference Voltage			0.70			V
$V_{VOUT}$	VOUT Feedback Voltage Comparator Threshold Accuracy	$V_{IN} = 3.0V$	$T_A = 25^{\circ}C$	-1.5	0	1.5	%
			$T_A = -40^{\circ}C$ to $85^{\circ}C$	-2.5	0	2.5	
	DC output voltage load regulation	$I_{OUT} = 1mA$ to $50mA$ $V_{IN} = 3.0V$ , $V_{OUT} = 2.1V$		-0.01			%/mA
	DC output voltage line regulation	$I_{OUT} = 20 mA$ , $2.4V \leq V_{IN} \leq 3.9V$		0.01			%/V
$I_{LK\_SW}$	Leakage current into SW pin	$V_{IN} = V_{OUT} = V_{SW} = 3.0V$ , $ON/Byp = GND$ (2)		0.0	100	nA	

(2) The internal resistor divider network is disconnected from VOUT pin.

### DRY PACKAGE (TOP VIEW)

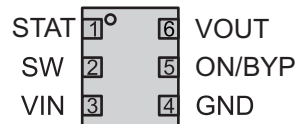

### PIN FUNCTIONS

PIN		I/O	DESCRIPTION
NAME	NO		
VIN	3	PWR	$V_{IN}$ power supply pin. Connect this pin close to the VIN terminal of the input capacitor. A ceramic capacitor of $2.2\mu F$ is required.
GND	4	PWR	GND supply pin. Connect this pin close to the GND terminal of the input and output capacitor.
ON/BYP	5	IN	This is the mode selection pin of the device. Pulling this pin to low forces the device into ultra low power bypass mode. The output of the DC/DC converter is connected to VIN via an internal bypass switch. Pulling this pin to high enables the DC/DC converter operation. This pin must be terminated and is controlled by the system. In case of CC2540, connect this to the power down signal which is output on one of the P1.x ports (see CC2540 user guide).
SW	2	OUT	This is the switch pin and is connected to the internal MOSFET switches. Connect the inductor to this terminal.
VOUT	6	IN	Feedback Pin for the internal feedback divider network and regulation loop. The internal bypass switch is connected between this pin and VIN. Connect this pin directly to the output capacitor with short trace.
STAT	1	OUT	This is the open drain status output with active low level. An internal comparator drives this output. The pin is high impedance with $ON/BYP = low$ . With $ON/BYP$ set to high the device and the internal VOUT comparator becomes active. The STAT pin is set to low once the output voltage is higher than 93% of nominal VOUT and high impedance once it is below this threshold. If not used, this pin can be left open.

FUNCTIONAL BLOCK DIAGRAM

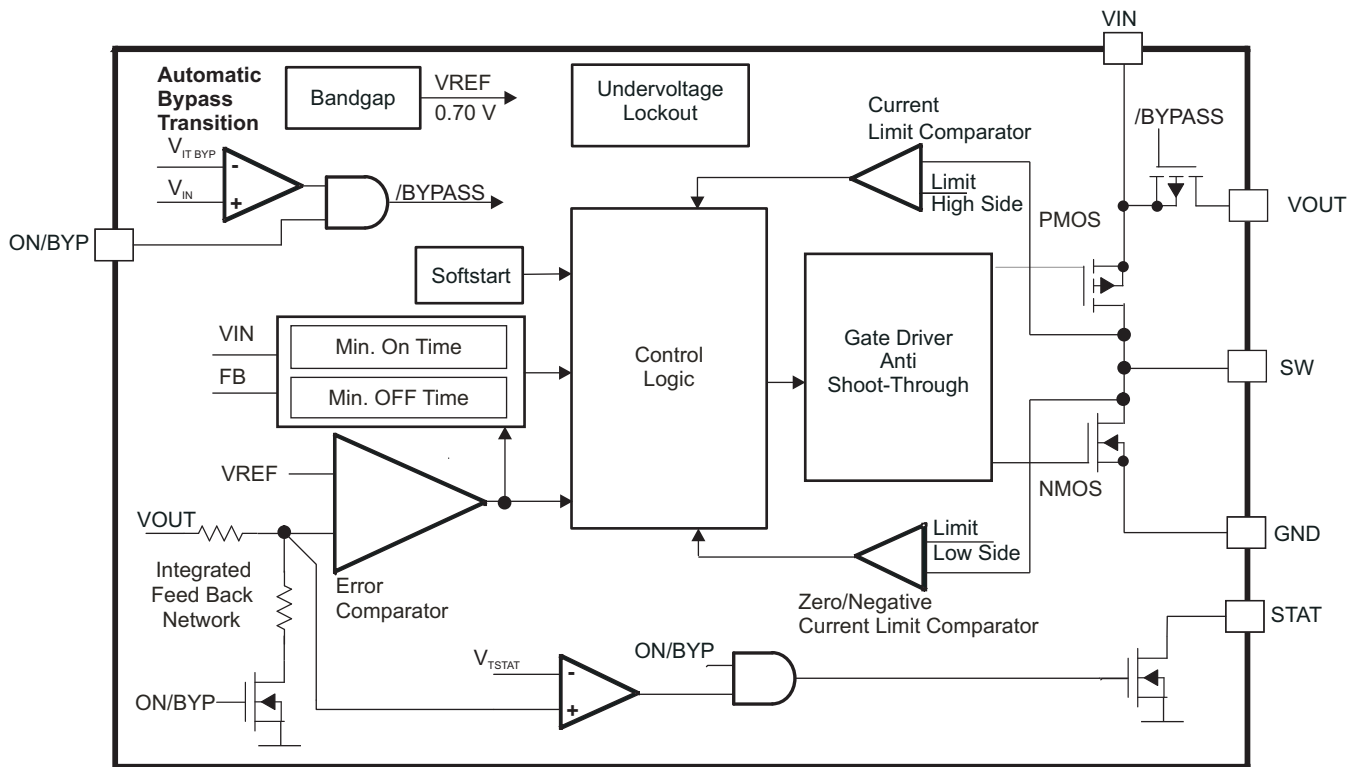

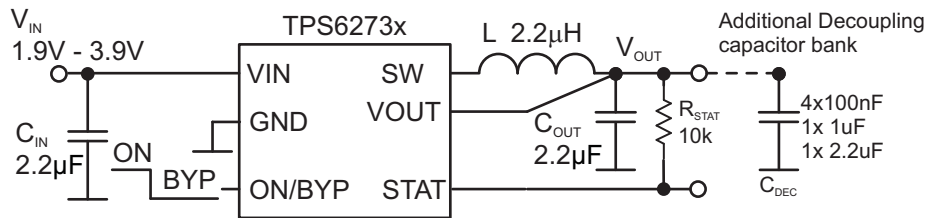
**PARAMETER MEASUREMENT INFORMATION**

 $C_{IN}, C_{OUT}$ : Murata GRM155R60J225ME15D 2.2  $\mu$ F 0402 size

 $C_{Load}$ : 4 x Murata GRM155R61A104KA01D 100nF

 1 x 2.2  $\mu$ F GRM155R60J225ME15D

 1 x 1 $\mu$ F GRM155R61A105KE15D

 L: Murata LQM21PN2R2NGC 2.2  $\mu$ H, FDK MIPSZ2012 2R2

**TYPICAL CHARACTERISTICS**
**Table of Graphs**

			FIGURE
$\eta$	Efficiency	vs Output current	1
$\eta$	Efficiency	vs Input voltage	2
$V_{OUT}$	Output voltage	vs Output current	3
	Output Voltage	vs Input voltage	4
$I_{SD}$	Shutdown current bypass mode	vs Input voltage	5
$I_Q$	Operating quiescent current	vs Input voltage	6
$r_{DS(ON)}$	Bypass Drain-source on-state resistance	vs Input voltage and ambient temperature	7
	PMOS Static drain-source on-state resistance	vs Input voltage and ambient temperature	8
	NMOS Static drain-source on-state resistance	vs Input voltage and ambient temperature	9
	Automatic transition into bypass	Falling $V_{IN}$	10
	Automatic transition into bypass	Rising $V_{IN}$	11
	Switching frequency	vs $I_{OUT}$ vs $V_{IN}$	12
$V_{OUT}$	Output ripple voltage	vs $I_{OUT}$ vs $V_{IN}$	13
	PSRR	vs Frequency	14
	Noise Density	vs Frequency	15
	DC/DC mode operation	$I_{OUT} = 10$ mA	16
		$I_{OUT} = 1$ mA	17
		$I_{OUT} = 18$ mA	18
		$I_{OUT} = 50$ mA	19
	DC/DC mode operation line and load transient performance		20
	Automatic bypass transition with falling/rising input voltage		21
	DC/DC mode $V_{OUT}$ AC load regulation performance		22
	Bypass mode operation $V_{OUT}$ AC behavior ON/BYP = GND		23
	Startup behavior		24
	Spurious output noise		25
	Battery current reduction	vs Battery voltage	26
	Mode transition ON/BYP behavior		27

TYPICAL CHARACTERISTICS (continued)

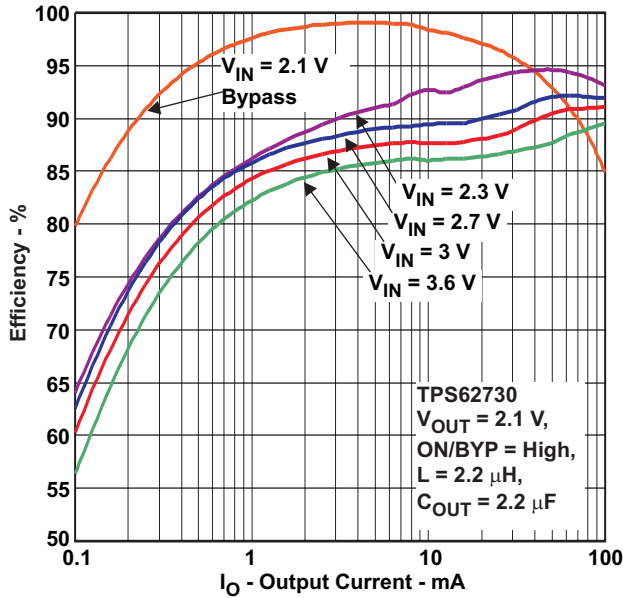

Figure 1. Efficiency vs Output Current

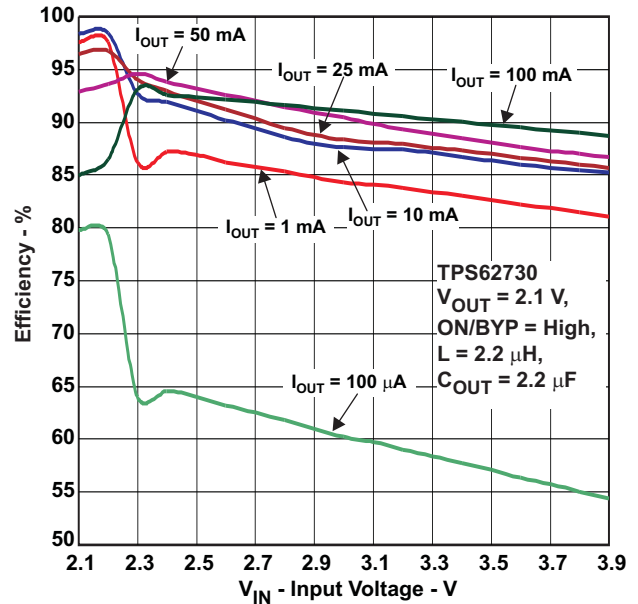

Figure 2. Efficiency vs Input Voltage

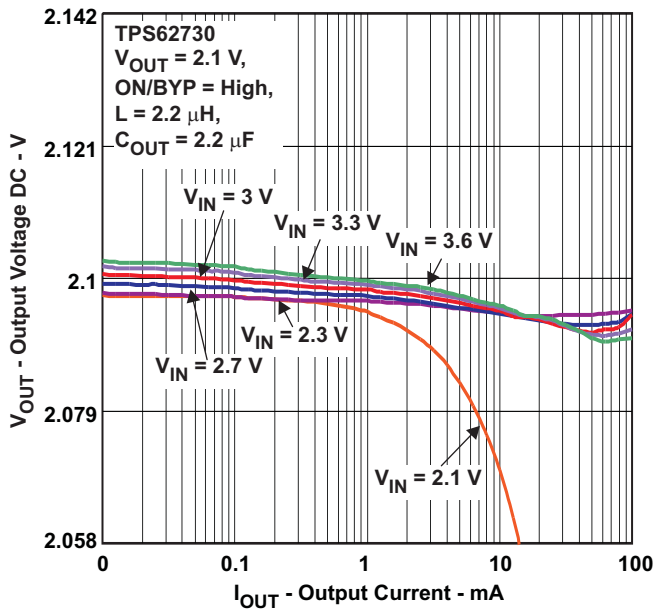

Figure 3. Output Voltage vs Output Current

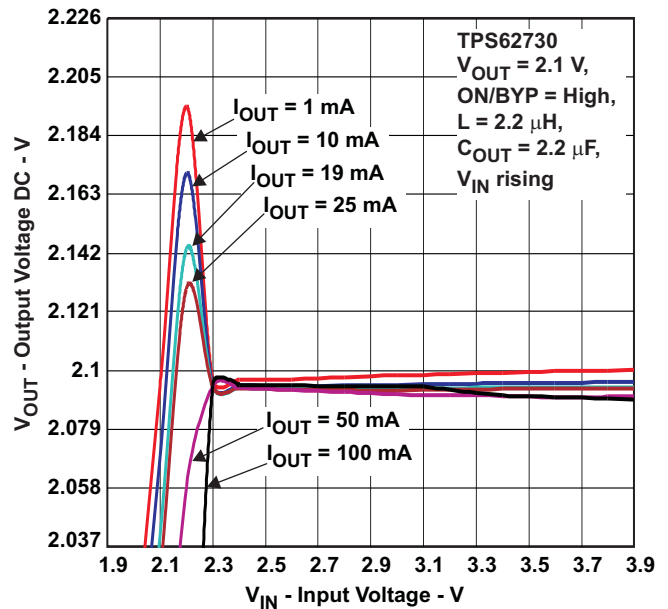

Figure 4. Output Voltage vs Input Voltage

TYPICAL CHARACTERISTICS (continued)

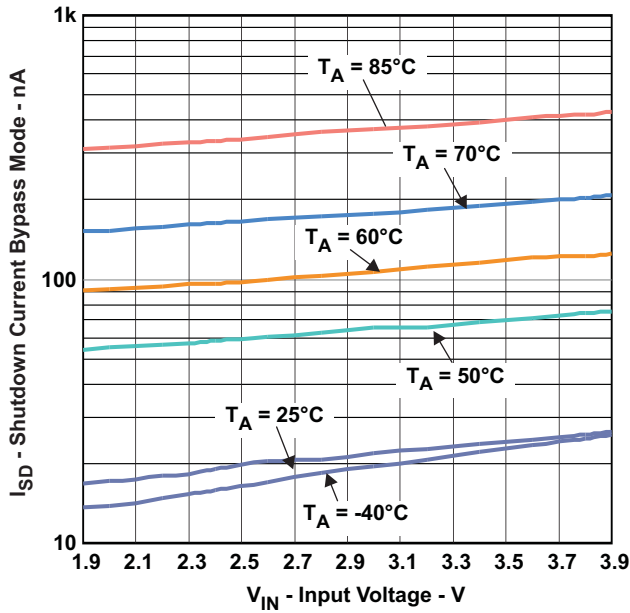

Figure 5. Shutdown Current Bypass Mode vs Input Voltage

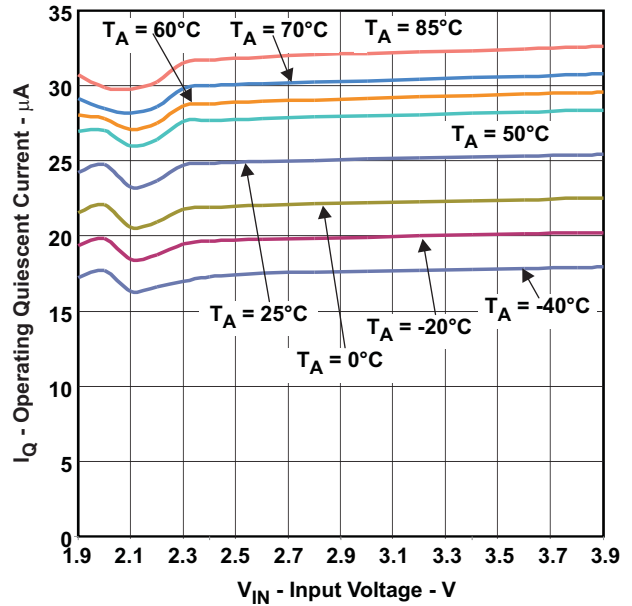

Figure 6. Operating Quiescent Current vs Input Voltage

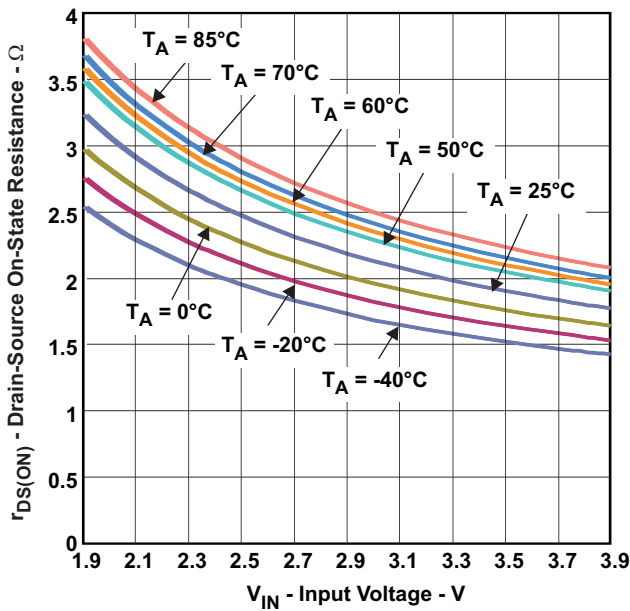

Figure 7.  $r_{DS(ON)}$  Bypass vs Input Voltage

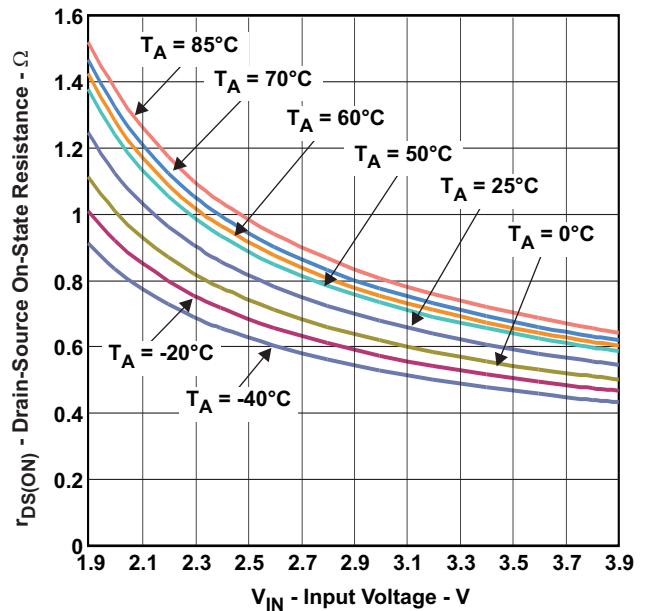

Figure 8.  $r_{DS(ON)}$  PMOS vs Input Voltage

TYPICAL CHARACTERISTICS (continued)

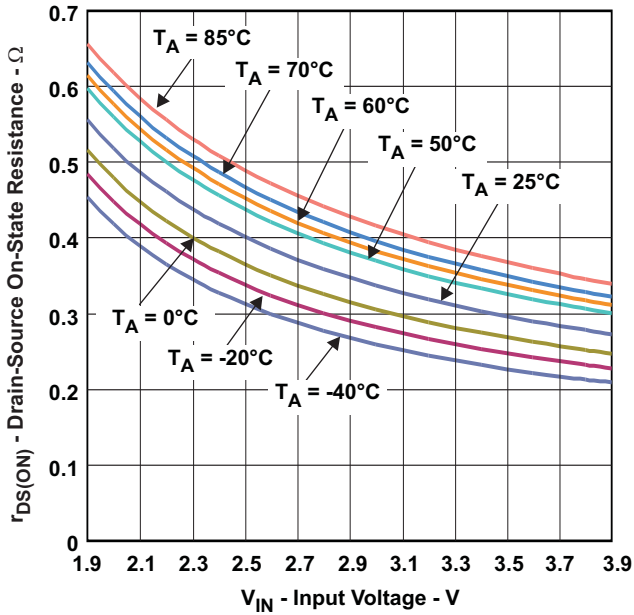

Figure 9.  $r_{DS(ON)}$  NMOS vs Input Voltage

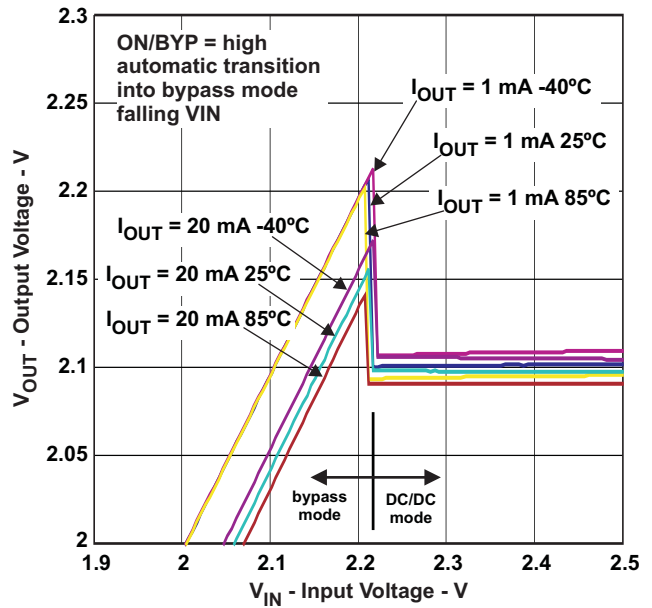

Figure 10. Automatic Transition into Bypass Mode - Falling  $V_{IN}$

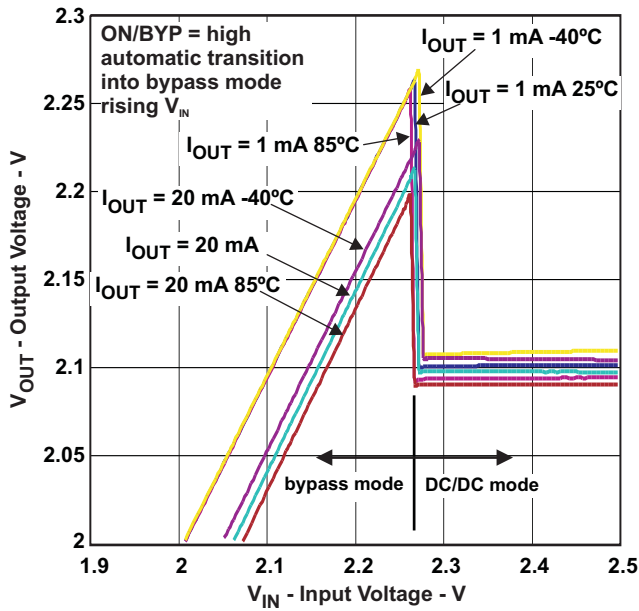

Figure 11. Automatic Transition into Bypass Mode - Rising  $V_{IN}$

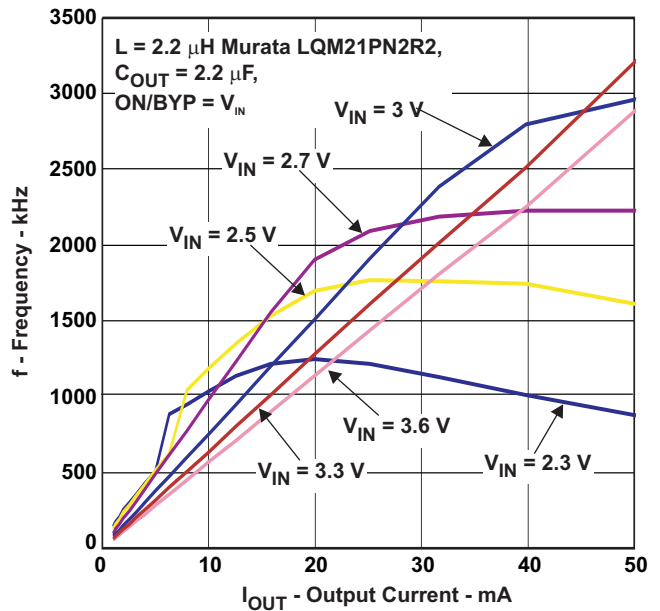

Figure 12. Switching Frequency vs  $I_{OUT}$  vs  $V_{IN}$

TYPICAL CHARACTERISTICS (continued)

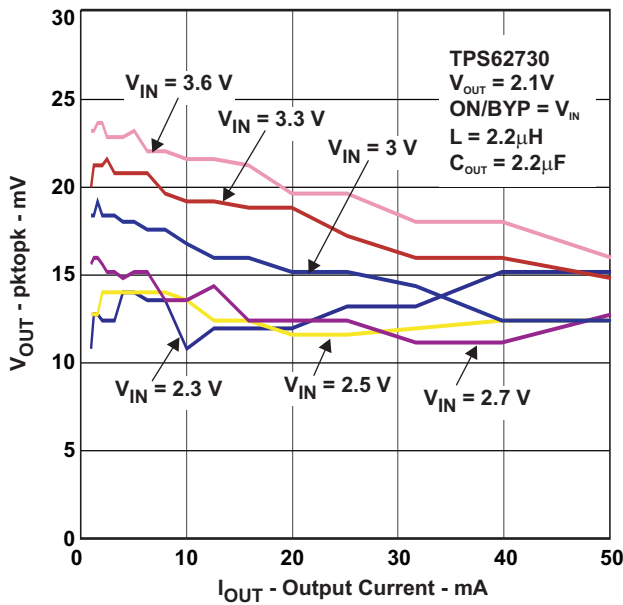

Figure 13.  $V_{OUT}$  vs  $I_{OUT}$  vs  $V_{IN}$

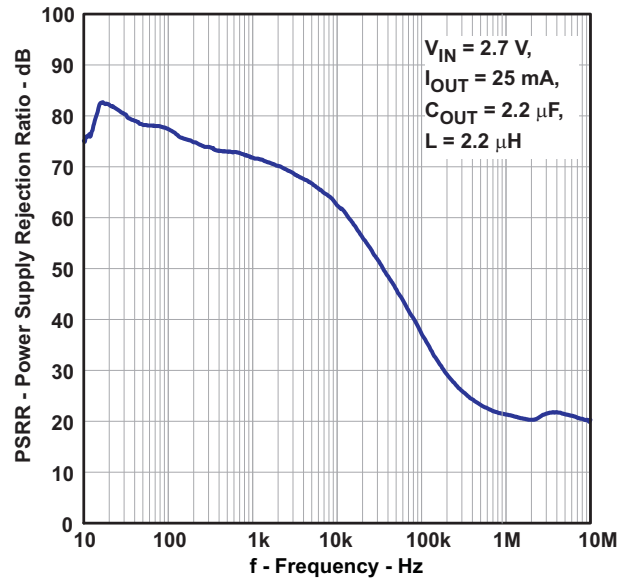

Figure 14. PSRR vs Frequency

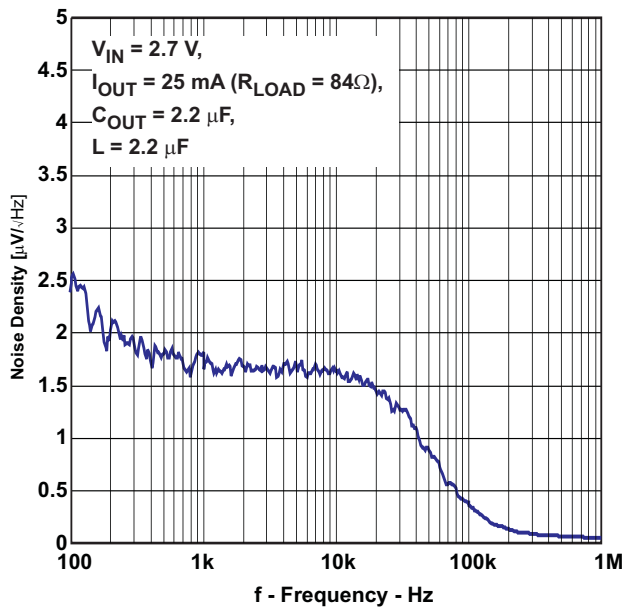

Figure 15. Noise Density vs Frequency

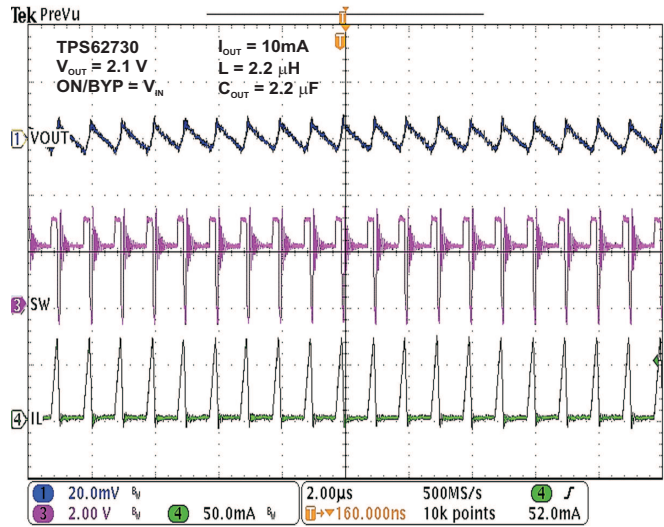

Figure 16. DC/DC Mode Operation  $I_{OUT} = 10\text{mA}$

TYPICAL CHARACTERISTICS (continued)

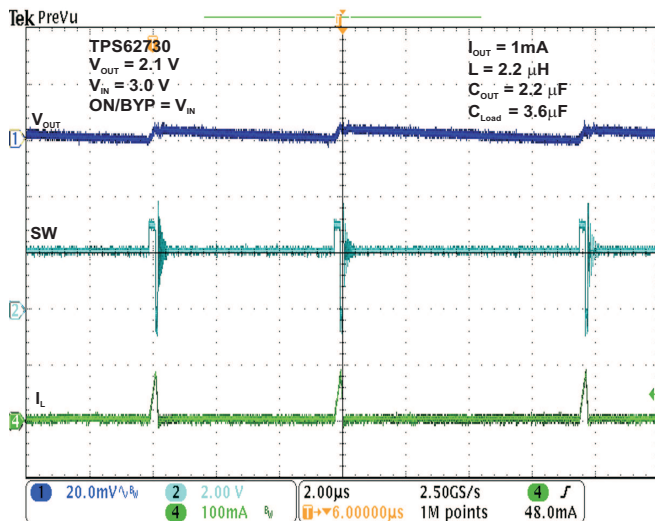

Figure 17. DC/DC Mode Operation  $I_{OUT} = 1\text{ mA}$

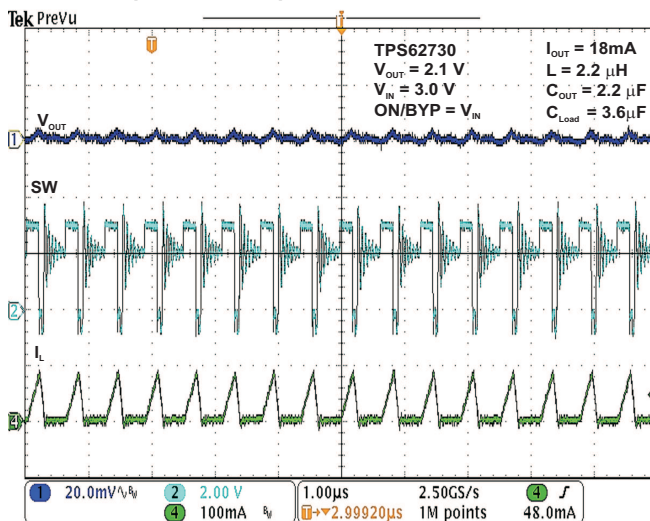

Figure 18. DC/DC Mode Operation  $I_{OUT} = 18\text{ mA}$

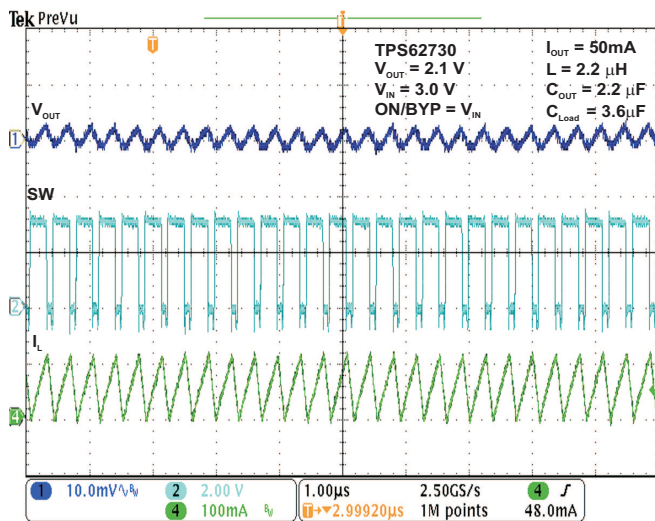

Figure 19. DC/DC Mode Operation  $I_{OUT} = 50\text{ mA}$

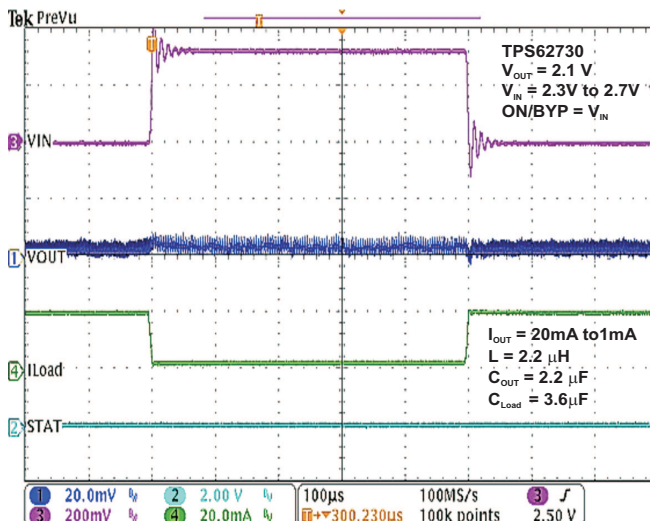

Figure 20. DC/DC Mode Operation Line and Load Transient Performance

TYPICAL CHARACTERISTICS (continued)

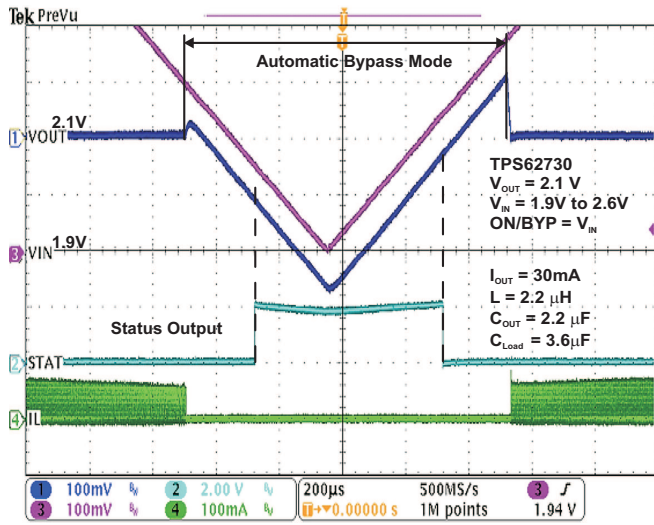

Figure 21. Automatic Bypass Transition with Falling / Rising Input Voltage  $V_{IN}$

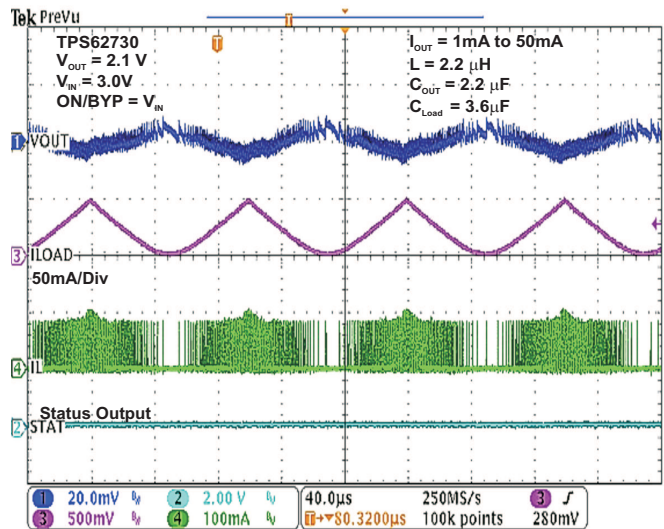

Figure 22. DC/DC Mode  $V_{OUT}$  AC Load Regulation Performance

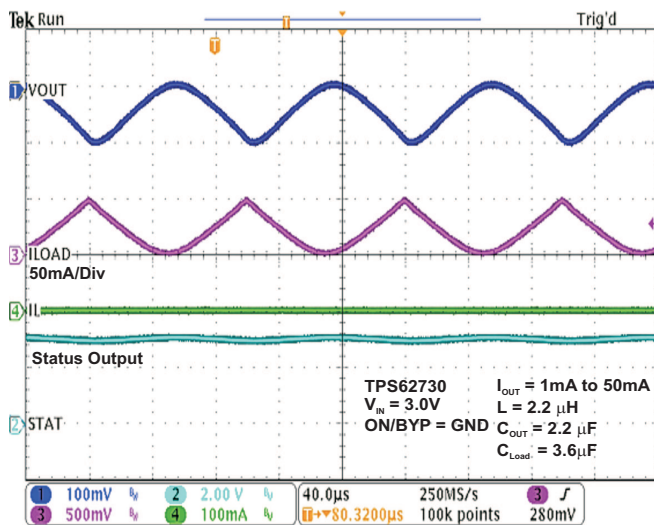

Figure 23. Bypass Mode Operation  $V_{OUT}$  AC Behavior  $ON/BYP = GND$

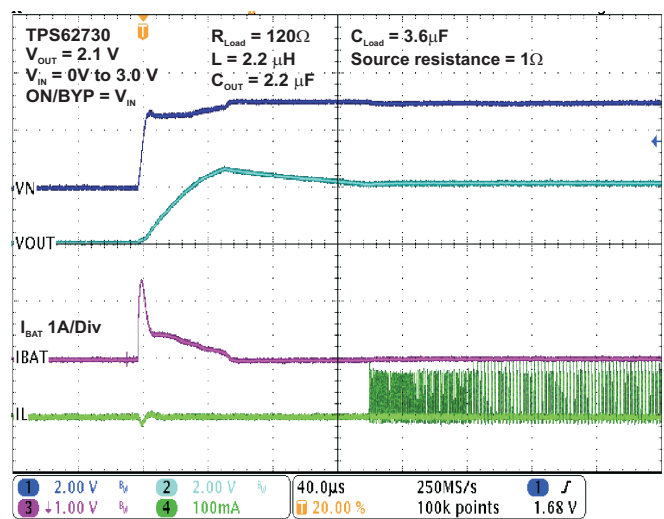

Figure 24. Startup Behavior

TYPICAL CHARACTERISTICS (continued)

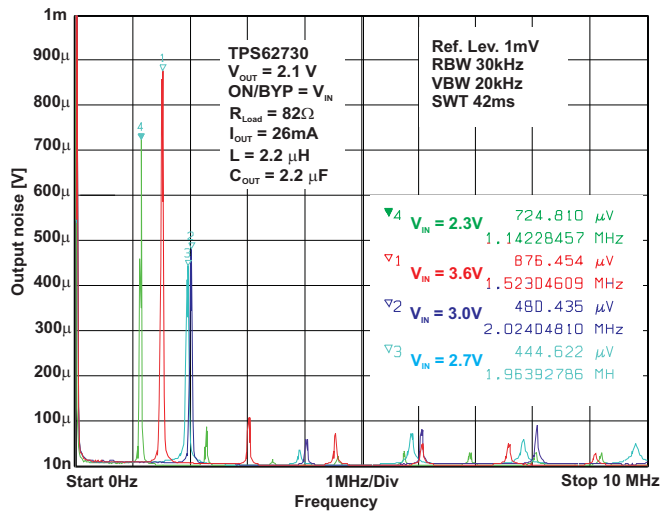

Figure 25. Spurious Output Noise TPS62730 I<sub>OUT</sub> 26mA

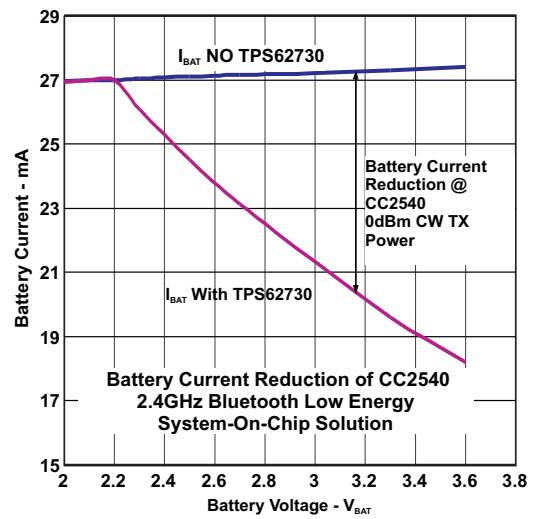

Figure 26. Battery Current Reduction vs Battery Voltage

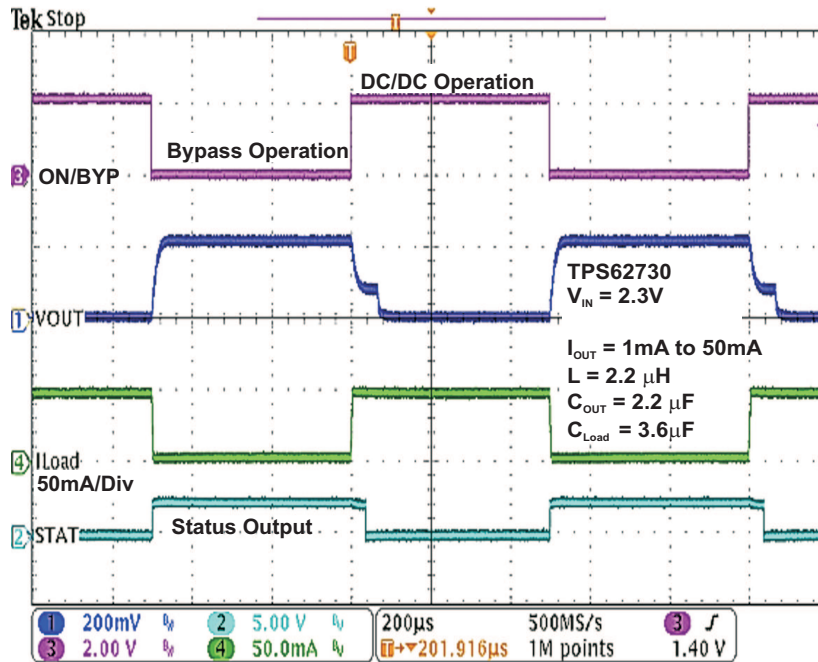

Figure 27. Mode Transition ON/BYP Behavior

## DETAILED DESCRIPTION

The TPS62730 combines a synchronous buck converter for high efficient voltage conversion and an integrated ultra low power bypass switch to support low power modes of modern micro controllers and RF IC's. The synchronous buck converter includes TI's DCS-Control™, an advanced regulation topology, that combines the advantages of hysteretic and voltage mode control architectures. While a comparator stage provides excellent load transient response, an additional voltage feedback loop ensures high DC accuracy as well. The DCS-Control™ enables switch frequencies up to 3MHz, excellent transient and AC load regulation as well as operation with small and cost competitive external components. The TPS6273x devices offer fixed output voltage options featuring smallest solution size by using only three external components. Furthermore this step down converter provides excellent low output voltage ripple over the entire load range which makes this part ideal for RF applications. In the ultra low power bypass mode, the output of the device VOUT is directly connected to the input VIN via the internal bypass switch. In this mode, the buck converter is shut down and consumes only 30nA typical input current. Once the device is turned from ultra low power bypass mode into buck converter operation for a RF transmission, all the internal circuits of the regulator are activated within a start up time tStart of typ. 50µs. During this time the bypass switch is still turned on and maintains the output VOUT connected to the input VIN. Once the DC/DC converter is settled and ready to operate, the internal bypass switch is turned off and the system is supplied by the output capacitor and the other decoupling capacitors. The buck converter kicks in once the capacitors connected to VOUT are discharged to the level of the nominal buck converter output voltage. Once the output voltage falls below the threshold of the internal error comparator, a switch pulse is initiated, and the high side switch of the DC/DC converter is turned on. It remains turned on until a minimum on time of tONmin expires and the output voltage trips the threshold of the error comparator or the inductor current reaches the high side switch current limit. Once the high side switch turns off, the low side switch rectifier is turned on and the inductor current ramps down until the high side switch turns on again or the inductor current reaches zero. The converter operates in the PFM (Pulse Frequency Modulation) mode during light loads, which maintains high efficiency over a wide load current range. In PFM Mode, the device starts to skip switch pulses and generates only single pulses with an on time of tONmin. The PFM mode of TPS62730 is optimized for low output ripple voltage if small external components are used.

The on time tONmin can be estimated to:

$$t_{ONmin} = \frac{V_{OUT}}{V_{IN}} \times 260 \text{ ns} \quad (1)$$

Therefore, the peak inductor current in PFM mode is approximately:

$$I_{LPMpeak} = \frac{(V_{IN} - V_{OUT})}{L} \times t_{ONmin} \quad (2)$$

With

- tONmin: High side switch on time [ns]
- VIN: Input voltage [V]
- VOUT: Output voltage [V]
- L : Inductance [µH]
- ILPMpeak : PFM inductor peak current [mA]

## ON/BYP MODE SELECTION

The DC/DC converter is activated when ON/BYP is set high. For proper operation, the ON/BYP pin must be terminated and may not be left floating. This pin is controlled by the RF transceiver or micro controller for proper mode selection. Pulling the ON/BYP pin low activates the Ultra Low Power Bypass Mode with typical 30nA current consumption. In this mode, the internal bypass switch is turned on and the output of the DC/DC converter is connected to the battery VIN. All other circuits like the entire internal-control circuitry, the High Side and Low Side MOSFET's of the DC/DC output stage are turned off as well the internal resistor feedback divider is disconnected. The ON/BYP need to be controlled by a Micro controller for proper mode selection.

## START UP

Once the device is supplied with a battery voltage, the bypass switch is activated. If the ON/BYP pin is set to high, the device operates in bypass mode until the DC/DC converter has settled and can kick in. During start up, high peak currents can flow over the bypass switch to charge up the output capacitor and the additional decoupling capacitors in the system.

## AUTOMATIC TRANSITION FROM DC/DC TO BYPASS OPERATION

With pin ON/BYP set to high, the TPS62730 features an automatic transition between DC/DC and bypass mode to reduce the output ripple voltage to zero. Once the input voltage comes close to the output voltage of the DC/DC converter, the DC/DC converter operates close to 100% duty cycle operation. At this operating condition, the switch frequency would start to drop and would lead to increased output ripple voltage. The internal bypass switch is turned on once the battery voltage at VIN trips the Automatic Bypass Transition Threshold VIT BYP for falling VIN. The DC/DC regulator is turned off and therefore it generates no output ripple voltage. Due to the output is connected via the bypass switch to the input, the output voltage follows the input voltage minus the voltage drop across the internal bypass switch. In this mode the current consumption of the DC/DC converter is reduced to typically 23µA. Once the input voltage increases and trips the bypass deactivation threshold VIT BYP for rising VIN, the DC/DC regulator turns on and the bypass switch is turned off.

## INTERNAL CURRENT LIMIT

The TPS62730 integrates a High Side and Low Side MOSFET current limit to protect the device against heavy load or short circuit when the DC/DC converter is active. The current in the switches is monitored by current limit comparators. When the current in the High Side MOSFET reaches its current limit, the High Side MOSFET is turned off and the Low Side MOSFET is turned on to ramp down the current in the inductor. The High Side MOSFET switch can only turn on again, once the current in the Low Side MOSFET switch has decreased below the threshold of its current limit comparator. The bypass switch doesn't feature a current limit to support lowest current consumption.

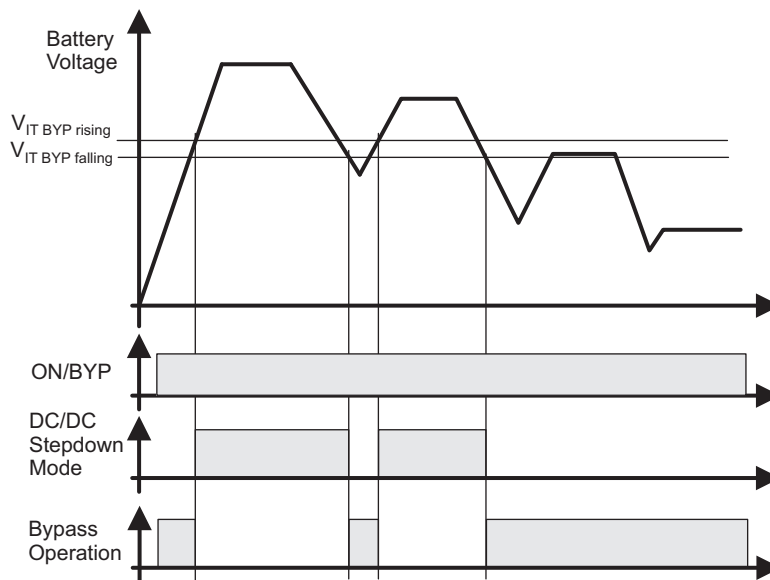

Figure 28. Operation Mode Diagram with ON/BYP = High

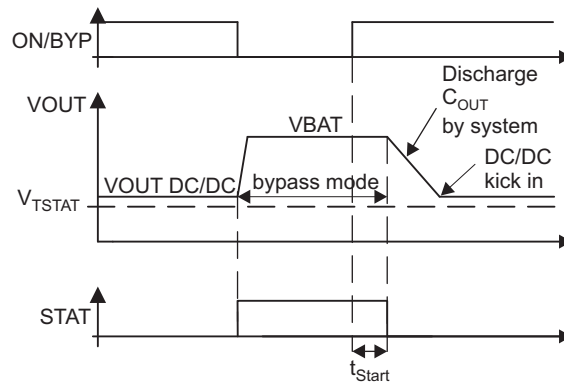

Figure 29. Signal Status Diagram ON/BYP, VOUT, STAT

APPLICATION INFORMATION

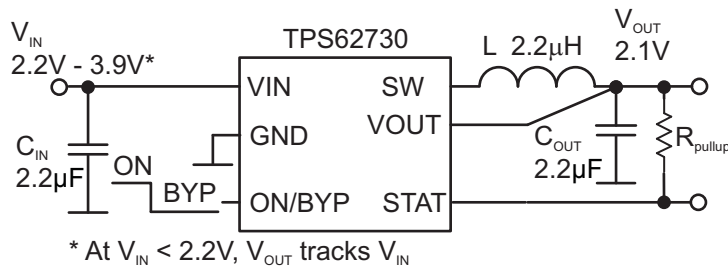

Figure 30. Typical Application

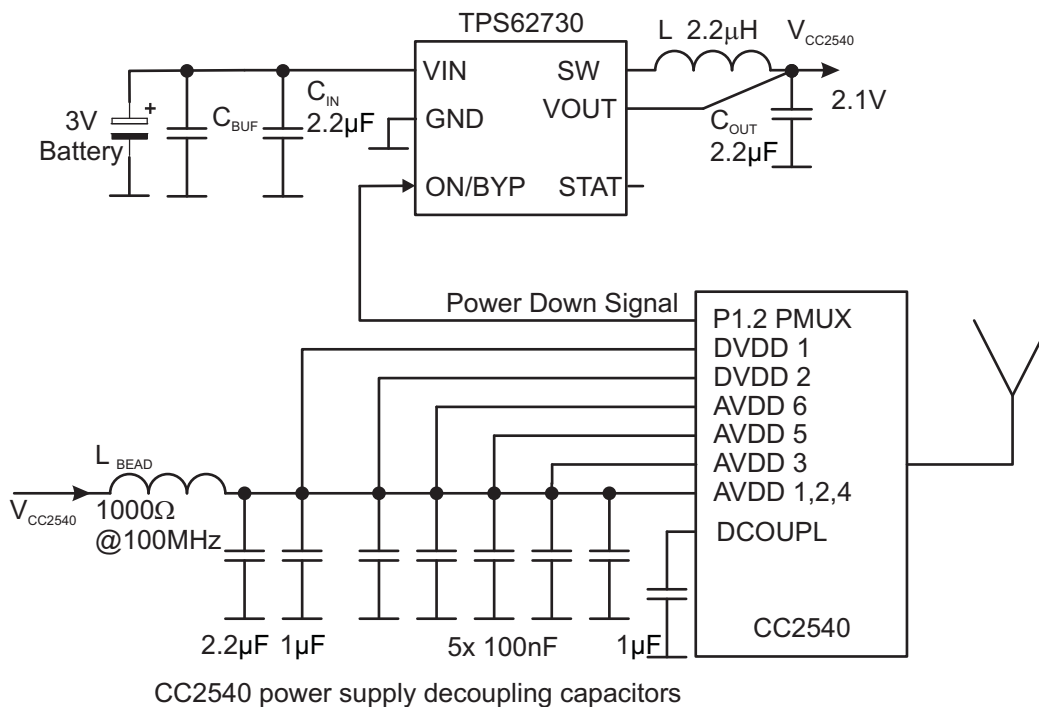
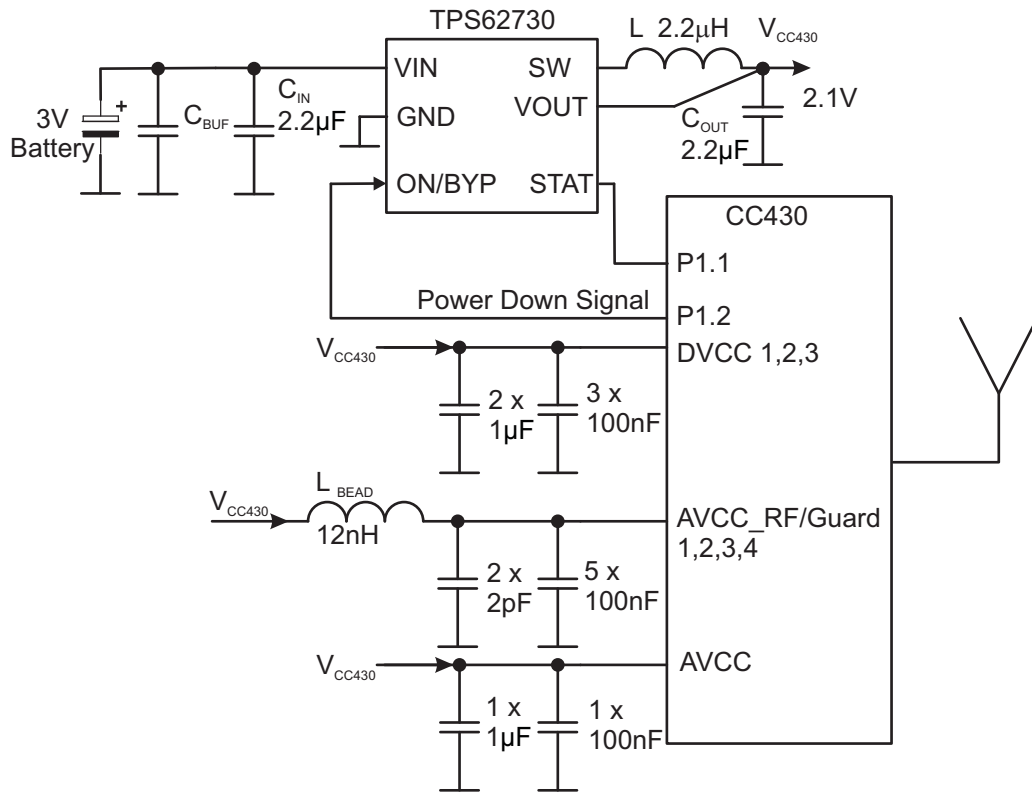

Figure 31. Application Example CC2540



CC430 power supply decoupling capacitors

**Figure 32. Application Example CC430**

## OUTPUT FILTER DESIGN (INDUCTOR AND OUTPUT CAPACITOR)

The TPS62730 is optimized to operate with effective inductance values in the range of 1.5µH to 3µH and with effective output capacitance in the range of 1.0µF to 10µF. The internal compensation is optimized to operate with an output filter of  $L = 2.2\mu\text{H}$  and  $C_{\text{OUT}} = 2.2\mu\text{F}$ , which gives an LC output filter corner frequency of:

$$f_c = \frac{1}{2 \times \pi \times \sqrt{(2.2\mu\text{H} \times 2.2\mu\text{F})}} = 72\text{kHz} \quad (3)$$

## INDUCTOR SELECTION

The inductor value affects its peak-to-peak ripple current, the PWM-to-PFM transition point, the output voltage ripple and the efficiency. The selected inductor has to be rated for its dc resistance and saturation current. The inductor ripple current ( $\Delta I_L$ ) decreases with higher inductance and increases with higher  $V_{\text{IN}}$  or  $V_{\text{OUT}}$ . Equation 4 calculates the maximum inductor current under static load conditions. The saturation current of the inductor should be rated higher than the maximum inductor current as calculated with Equation 5

$$\Delta I_L = V_{\text{out}} \times \frac{1 - \frac{V_{\text{out}}}{V_{\text{in}}}}{L \times f} \quad (4)$$

$$I_{L\text{max}} = I_{\text{outmax}} + \frac{\Delta I_L}{2} \quad (5)$$

With:

f = Switching Frequency

L = Inductor Value

$\Delta I_L$  = Peak to Peak inductor ripple current

$I_{L\text{max}}$  = Maximum Inductor current

In high-frequency converter applications, the efficiency is essentially affected by the inductor AC resistance (i.e., quality factor) and to a smaller extent by the inductor DCR value. To achieve high efficiency operation, care should be taken in selecting inductors featuring a quality factor above 25 at the switching frequency. Increasing the inductor value produces lower RMS currents, but degrades transient response. For a given physical inductor size, increased inductance usually results in an inductor with lower saturation current.

The total losses of the coil consist of both the losses in the DC resistance,  $R_{\text{(DC)}}$ , and the following frequency-dependent components:

- The losses in the core material (magnetic hysteresis loss, especially at high switching frequencies)
- Additional losses in the conductor from the skin effect (current displacement at high frequencies)
- Magnetic field losses of the neighboring windings (proximity effect)
- Radiation losses

The following inductor series from different suppliers have been used with the TPS62730 converters.

**Table 1. List of inductors**

INDUCTANCE [µH]	DIMENSIONS [mm3]	INDUCTOR TYPE	SUPPLIER
2.2	2.0 × 1.2 × 1.0	LQM21PN2R2NGC	Murata
2.2	2.0 × 1.2 × 1.0	MIPSZ2012	FDK

## DC/DC OUTPUT CAPACITOR SELECTION

The DCS-Control™ scheme of the TPS62730 allows the use of tiny ceramic capacitors. Ceramic capacitors with low ESR values have the lowest output voltage ripple and are recommended. The output capacitor requires either an X7R or X5R dielectric. Y5V and Z5U dielectric capacitors, aside from their wide variation in capacitance over temperature, become resistive at high frequencies. At light load currents the converter operates in Power Save Mode and the output voltage ripple is dependent on the output capacitor value and the PFM peak inductor current.

## ADDITIONAL DECOUPLING CAPACITORS

In addition to the output capacitor there are further decoupling capacitors connected to the output of the TPS62730. These decoupling capacitor are placed closely at the RF transmitter or micro controller. The total capacitance of these decoupling capacitors should be kept to a minimum and should not exceed the values given in the reference designs, see [Figure 31](#) and [Figure 32](#). During mode transition from DC/DC operation to bypass mode the capacitors on the output VOUT are charged up to the battery voltage VIN via the internal bypass switch. During mode transition from bypass mode to DC/DC operation, these capacitors need to be discharged by the system supply current to the nominal output voltage threshold until the DC/DC will kick in. The charge change in the output and decoupling capacitors can be calculated according to [Equation 6](#). The energy loss due to charge/discharge of the output and decoupling capacitors can be calculated according to [Equation 7](#)

$$dQ_{C_{OUT\_CDEC}} = C_{C_{OUT\_CDEC}} \times (V_{IN} - V_{OUT\_DC\_DC}) \quad (6)$$

$$E_{Charge\_Loss} = \frac{1}{2} \times C_{C_{OUT\_CDEC}} \times (V_{IN}^2 - V_{OUT\_DC\_DC}^2) \quad (7)$$

with

$dQ_{C_{OUT\_CDEC}}$  : Charge change needed to charge up / discharge the output and decoupling capacitors from VOUT\_DC\_DC to VIN and vice versa

$C_{C_{OUT\_CDEC}}$ : Total capacitance on the VOUT pin of the device, includes output and decoupling capacitors

VIN: Input (battery) voltage

VOUT\_DC\_DC: nominal DC/DC output voltage VOUT

## INPUT CAPACITOR SELECTION

Because of the nature of the buck converter having a pulsating input current, a low ESR input capacitor is required for best input voltage filtering to ensure proper function of the device and to minimize input voltage spikes. For most applications a 2.2µF to 4.7µF ceramic capacitor is recommended. The input capacitor can be increased without any limit for better input voltage filtering.

[Table 2](#) shows a list of tested input/output capacitors.

## INPUT BUFFER CAPACITOR SELECTION

In addition to the small ceramic input capacitor a larger buffer capacitor  $C_{Buf}$  is recommended to reduce voltage drops and ripple voltage. When using battery chemistries like Li-SOCl<sub>2</sub>, Li-SO<sub>2</sub>, Li-MnO<sub>2</sub>, the impedance of the battery has to be considered. These battery types tend to increase their impedance depending on discharge status and often can support output currents of only a few mA. Therefore a buffer capacitor is recommended to stabilize the battery voltage during DC/DC operations e.g. for a RF transmission. A voltage drop on the input of the TPS62730 during DC/DC operation impacts the advantage of the step down conversion for system power reduction. Furthermore the voltage drops can fall below the minimum recommended operating voltage of the device and leads to an early system cut off. Both impacts effects reduce the battery life time. To achieve best performance and to extract most energy out of the battery a good procedure is to design the select the buffer capacitor value for an voltage drop below 50mVpp during DC/DC operation. The capacitor value strongly depends on the used battery type, as well the current consumption during a RF transmission as well the duration of the transmission.

**Table 2. List of Capacitor**

CAPACITANCE [µF]	SIZE	CAPACITOR TYPE	SUPPLIER
2.2	0402	GRM155R60J225	Murata

## CHECKING LOOP STABILITY

The first step of circuit and stability evaluation is to look from a steady-state perspective at the following signals:

- Switching node, SW
- Inductor current, IL
- Output ripple voltage, VOUT(AC)

These are the basic signals that need to be measured when evaluating a switching converter. When the switching waveform shows large duty cycle jitter or the output voltage or inductor current shows oscillations, the regulation loop may be unstable. This is often a result of board layout and/or L-C combination.

As a next step in the evaluation of the regulation loop, the load transient response is tested. The time between the application of the load transient and the turn on of the High Side MOSFET, the output capacitor must supply all of the current required by the load.  $V_{OUT}$  immediately shifts by an amount equal to  $\Delta I_{(LOAD)} \times ESR$ , where ESR is the effective series resistance of  $C_{OUT}$ .  $\Delta I_{(LOAD)}$  begins to charge or discharge  $C_O$  generating a feedback error signal used by the regulator to return  $V_{OUT}$  to its steady-state value. The results are most easily interpreted when the device operates in PWM mode.

During this recovery time,  $V_{OUT}$  can be monitored for settling time, overshoot or ringing that helps judge the converter's stability. Without any ringing, the loop has usually more than 45° of phase margin.

Because the damping factor of the circuitry is directly related to several resistive parameters (e.g., MOSFET  $r_{DS(on)}$ ) that are temperature dependant, the loop stability analysis has to be done over the input voltage range, load current range, and temperature range.

### LAYOUT CONSIDERATIONS

As for all switching power supplies, the layout is an important step in the design. Especially RF designs demand careful attention to the PCB layout. Care must be taken in board layout to get the specified performance. If the layout is not carefully done, the regulator could show poor line and/or load regulation, stability issues as well as EMI problems and interference with RF circuits. It is critical to provide a low inductance, impedance ground path. Therefore, use wide and short traces for the main current paths. The input capacitor should be placed as close as possible to the IC pins as well as the inductor and output capacitor. Use a common Power GND node and a different node for the Signal GND to minimize the effects of ground noise. Keep the common path to the GND PIN, which returns the small signal components and the high current of the output capacitors as short as possible to avoid ground noise. The  $V_{OUT}$  line should be connected to the output capacitor and routed away from noisy components and traces (e.g. SW line).

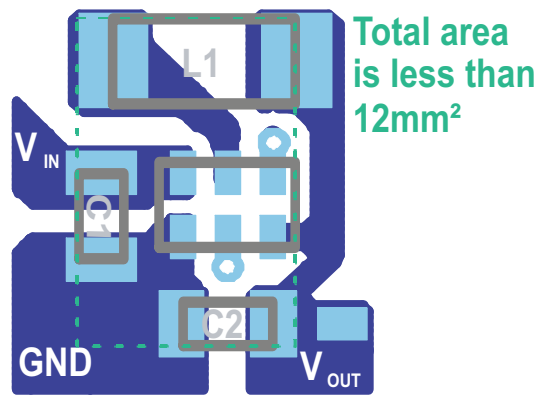

**Figure 33. Recommended PCB Layout for TPS62730**

**PACKAGING INFORMATION**

Orderable Device	Status <sup>(1)</sup>	Package Type	Package Drawing	Pins	Package Qty	Eco Plan <sup>(2)</sup>	Lead/ Ball Finish	MSL Peak Temp <sup>(3)</sup>	Samples (Requires Login)
TPS62730DRYR	ACTIVE	SON	DRY	6	5000	Green (RoHS & no Sb/Br)	CU NIPDAU	Level-1-260C-UNLIM	
TPS62730DRYT	ACTIVE	SON	DRY	6	250	Green (RoHS & no Sb/Br)	CU NIPDAU	Level-1-260C-UNLIM	
TPS62733DRYR	PREVIEW	SON	DRY	6	5000	Green (RoHS & no Sb/Br)	CU NIPDAU	Level-1-260C-UNLIM	
TPS62733DRYT	PREVIEW	SON	DRY	6	250	Green (RoHS & no Sb/Br)	CU NIPDAU	Level-1-260C-UNLIM	

<sup>(1)</sup> The marketing status values are defined as follows:

**ACTIVE:** Product device recommended for new designs.

**LIFEBUY:** TI has announced that the device will be discontinued, and a lifetime-buy period is in effect.

**NRND:** Not recommended for new designs. Device is in production to support existing customers, but TI does not recommend using this part in a new design.

**PREVIEW:** Device has been announced but is not in production. Samples may or may not be available.

**OBSOLETE:** TI has discontinued the production of the device.

<sup>(2)</sup> Eco Plan - The planned eco-friendly classification: Pb-Free (RoHS), Pb-Free (RoHS Exempt), or Green (RoHS & no Sb/Br) - please check <http://www.ti.com/productcontent> for the latest availability information and additional product content details.

**TBD:** The Pb-Free/Green conversion plan has not been defined.

**Pb-Free (RoHS):** TI's terms "Lead-Free" or "Pb-Free" mean semiconductor products that are compatible with the current RoHS requirements for all 6 substances, including the requirement that lead not exceed 0.1% by weight in homogeneous materials. Where designed to be soldered at high temperatures, TI Pb-Free products are suitable for use in specified lead-free processes.

**Pb-Free (RoHS Exempt):** This component has a RoHS exemption for either 1) lead-based flip-chip solder bumps used between the die and package, or 2) lead-based die adhesive used between the die and leadframe. The component is otherwise considered Pb-Free (RoHS compatible) as defined above.

**Green (RoHS & no Sb/Br):** TI defines "Green" to mean Pb-Free (RoHS compatible), and free of Bromine (Br) and Antimony (Sb) based flame retardants (Br or Sb do not exceed 0.1% by weight in homogeneous material)

<sup>(3)</sup> MSL, Peak Temp. -- The Moisture Sensitivity Level rating according to the JEDEC industry standard classifications, and peak solder temperature.

**Important Information and Disclaimer:** The information provided on this page represents TI's knowledge and belief as of the date that it is provided. TI bases its knowledge and belief on information provided by third parties, and makes no representation or warranty as to the accuracy of such information. Efforts are underway to better integrate information from third parties. TI has taken and continues to take reasonable steps to provide representative and accurate information but may not have conducted destructive testing or chemical analysis on incoming materials and chemicals. TI and TI suppliers consider certain information to be proprietary, and thus CAS numbers and other limited information may not be available for release.

In no event shall TI's liability arising out of such information exceed the total purchase price of the TI part(s) at issue in this document sold by TI to Customer on an annual basis.

## TAPE AND REEL INFORMATION

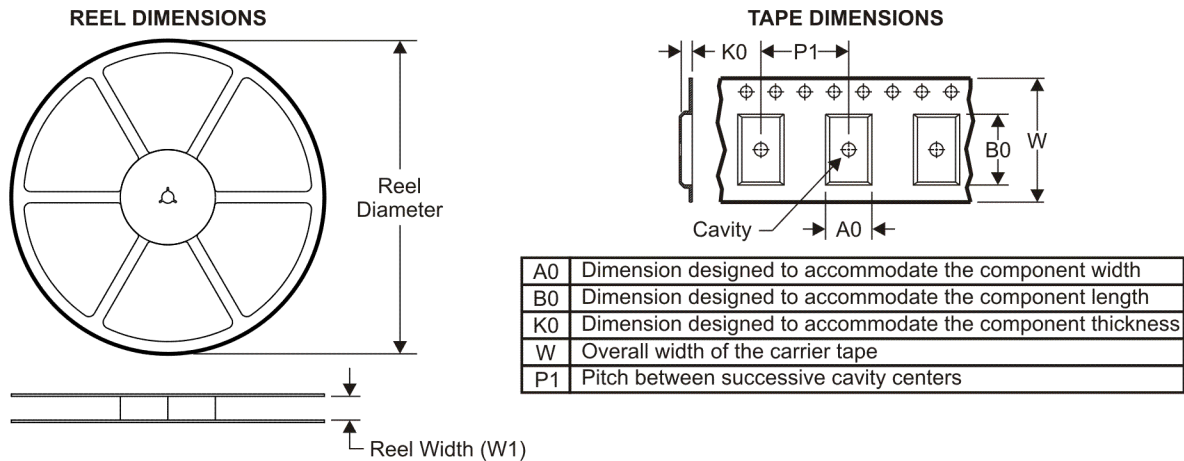

### QUADRANT ASSIGNMENTS FOR PIN 1 ORIENTATION IN TAPE

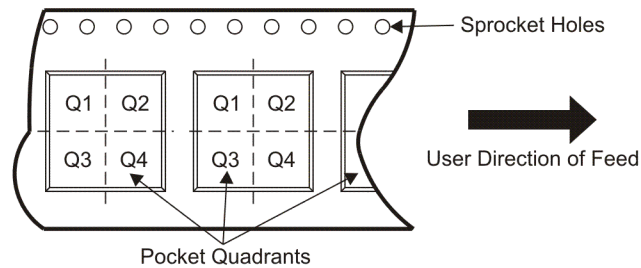

\*All dimensions are nominal

Device	Package Type	Package Drawing	Pins	SPQ	Reel Diameter (mm)	Reel Width W1 (mm)	A0 (mm)	B0 (mm)	K0 (mm)	P1 (mm)	W (mm)	Pin1 Quadrant
TPS62730DRYR	SON	DRY	6	5000	179.0	8.4	1.2	1.65	0.7	4.0	8.0	Q1

TAPE AND REEL BOX DIMENSIONS

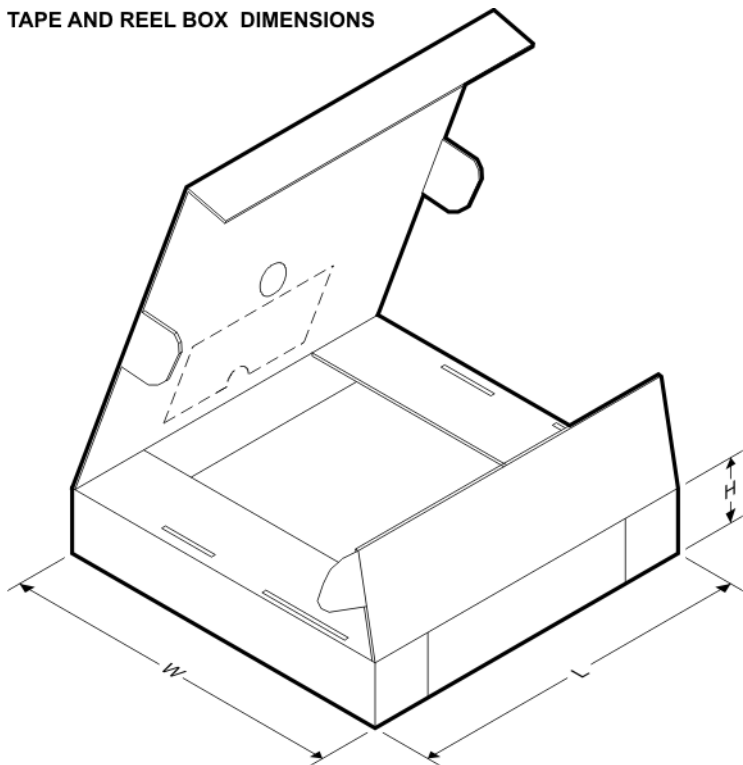

\*All dimensions are nominal

Device	Package Type	Package Drawing	Pins	SPQ	Length (mm)	Width (mm)	Height (mm)
TPS62730DRYR	SON	DRY	6	5000	203.0	203.0	35.0

DRY (R-PUSON-N6)

PLASTIC SMALL OUTLINE NO-LEAD

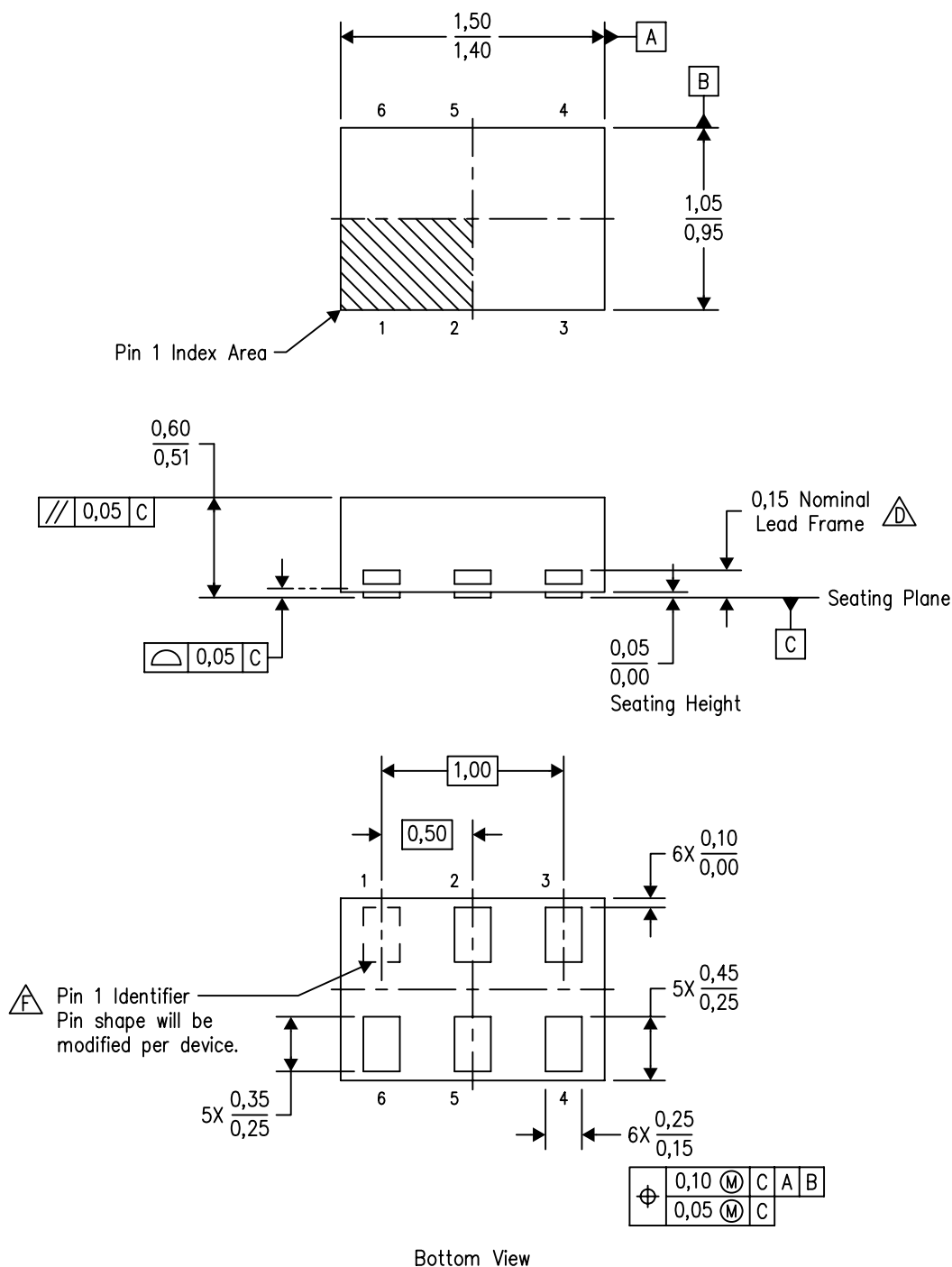

4207181/F 12/11

- NOTES:
- A. All linear dimensions are in millimeters. Dimensioning and tolerancing per ASME Y14.5M-1994.
  - B. This drawing is subject to change without notice.
  - C. SON (Small Outline No-Lead) package configuration.
  - $\triangle D$  The exposed lead frame feature on side of package may or may not be present due to alternative lead frame designs.
  - E. This package complies to JEDEC MO-287 variation UFAD.
  - $\triangle F$  See the additional figure in the Product Data Sheet for details regarding the pin 1 identifier shape.

DRY (S-PUSON-N6)

PLASTIC SMALL OUTLINE NO-LEAD

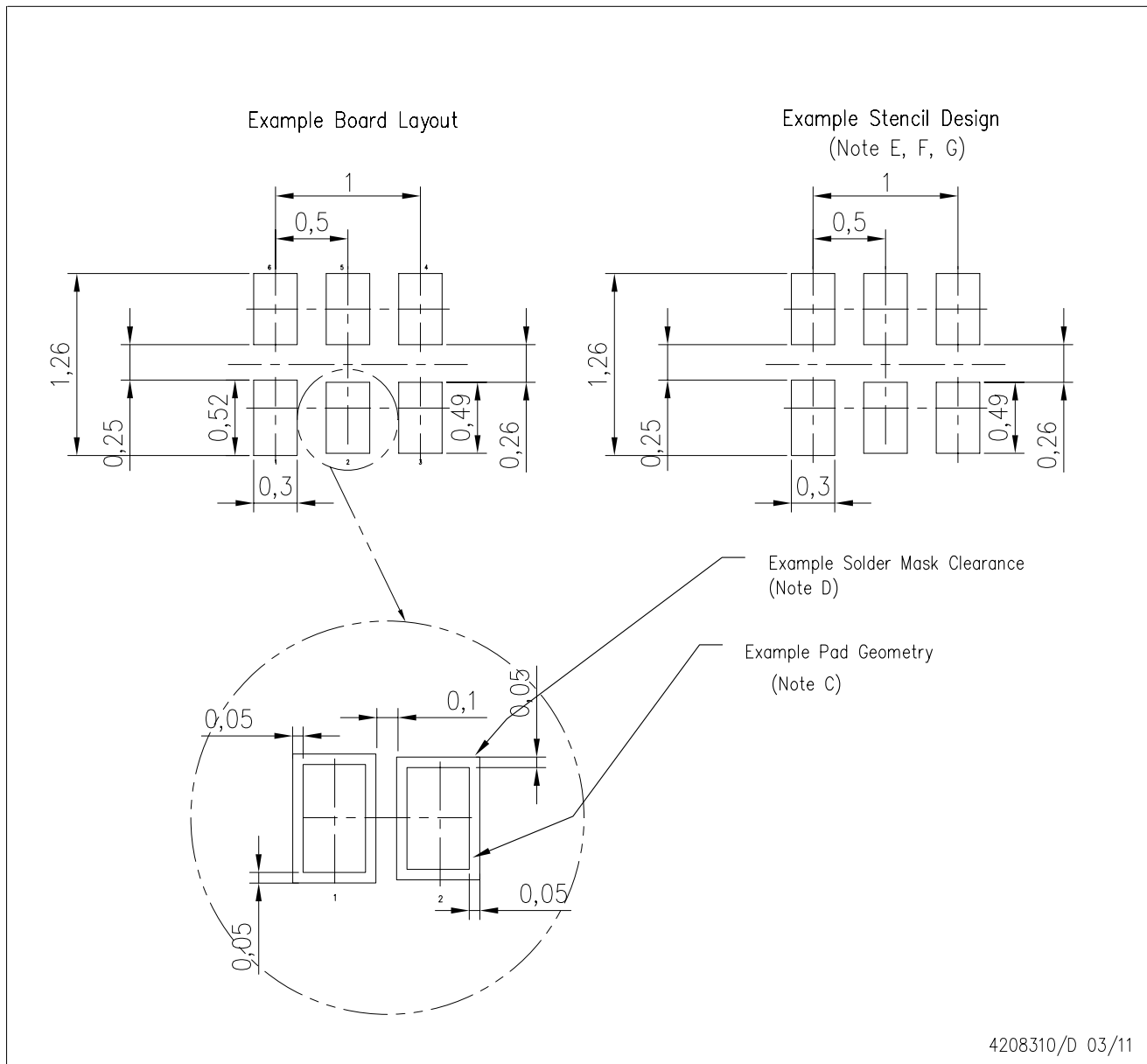

- NOTES:
- A. All linear dimensions are in millimeters.
  - B. This drawing is subject to change without notice.
  - C. Publication IPC-7351 is recommended for alternate designs.
  - D. Customers should contact their board fabrication site for minimum solder mask web tolerances between signal pads.
  - E. Maximum stencil thickness 0,127 mm (5 mils). All linear dimensions are in millimeters.
  - F. Laser cutting apertures with trapezoidal walls and also rounding corners will offer better paste release. Customers should contact their board assembly site for stencil design recommendations. Refer to IPC 7525 for stencil design considerations.
  - G. Side aperture dimensions over-print land for acceptable area ratio > 0.66. Customer may reduce side aperture dimensions if stencil manufacturing process allows for sufficient release at smaller opening.

## IMPORTANT NOTICE

Texas Instruments Incorporated and its subsidiaries (TI) reserve the right to make corrections, modifications, enhancements, improvements, and other changes to its products and services at any time and to discontinue any product or service without notice. Customers should obtain the latest relevant information before placing orders and should verify that such information is current and complete. All products are sold subject to TI's terms and conditions of sale supplied at the time of order acknowledgment.

TI warrants performance of its hardware products to the specifications applicable at the time of sale in accordance with TI's standard warranty. Testing and other quality control techniques are used to the extent TI deems necessary to support this warranty. Except where mandated by government requirements, testing of all parameters of each product is not necessarily performed.

TI assumes no liability for applications assistance or customer product design. Customers are responsible for their products and applications using TI components. To minimize the risks associated with customer products and applications, customers should provide adequate design and operating safeguards.

TI does not warrant or represent that any license, either express or implied, is granted under any TI patent right, copyright, mask work right, or other TI intellectual property right relating to any combination, machine, or process in which TI products or services are used. Information published by TI regarding third-party products or services does not constitute a license from TI to use such products or services or a warranty or endorsement thereof. Use of such information may require a license from a third party under the patents or other intellectual property of the third party, or a license from TI under the patents or other intellectual property of TI.

Reproduction of TI information in TI data books or data sheets is permissible only if reproduction is without alteration and is accompanied by all associated warranties, conditions, limitations, and notices. Reproduction of this information with alteration is an unfair and deceptive business practice. TI is not responsible or liable for such altered documentation. Information of third parties may be subject to additional restrictions.

Resale of TI products or services with statements different from or beyond the parameters stated by TI for that product or service voids all express and any implied warranties for the associated TI product or service and is an unfair and deceptive business practice. TI is not responsible or liable for any such statements.

TI products are not authorized for use in safety-critical applications (such as life support) where a failure of the TI product would reasonably be expected to cause severe personal injury or death, unless officers of the parties have executed an agreement specifically governing such use. Buyers represent that they have all necessary expertise in the safety and regulatory ramifications of their applications, and acknowledge and agree that they are solely responsible for all legal, regulatory and safety-related requirements concerning their products and any use of TI products in such safety-critical applications, notwithstanding any applications-related information or support that may be provided by TI. Further, Buyers must fully indemnify TI and its representatives against any damages arising out of the use of TI products in such safety-critical applications.

TI products are neither designed nor intended for use in military/aerospace applications or environments unless the TI products are specifically designated by TI as military-grade or "enhanced plastic." Only products designated by TI as military-grade meet military specifications. Buyers acknowledge and agree that any such use of TI products which TI has not designated as military-grade is solely at the Buyer's risk, and that they are solely responsible for compliance with all legal and regulatory requirements in connection with such use.

TI products are neither designed nor intended for use in automotive applications or environments unless the specific TI products are designated by TI as compliant with ISO/TS 16949 requirements. Buyers acknowledge and agree that, if they use any non-designated products in automotive applications, TI will not be responsible for any failure to meet such requirements.

Following are URLs where you can obtain information on other Texas Instruments products and application solutions:

### Products

Audio	<a href="http://www.ti.com/audio">www.ti.com/audio</a>
Amplifiers	<a href="http://amplifier.ti.com">amplifier.ti.com</a>
Data Converters	<a href="http://dataconverter.ti.com">dataconverter.ti.com</a>
DLP® Products	<a href="http://www.dlp.com">www.dlp.com</a>
DSP	<a href="http://dsp.ti.com">dsp.ti.com</a>
Clocks and Timers	<a href="http://www.ti.com/clocks">www.ti.com/clocks</a>
Interface	<a href="http://interface.ti.com">interface.ti.com</a>
Logic	<a href="http://logic.ti.com">logic.ti.com</a>
Power Mgmt	<a href="http://power.ti.com">power.ti.com</a>
Microcontrollers	<a href="http://microcontroller.ti.com">microcontroller.ti.com</a>
RFID	<a href="http://www.ti-rfid.com">www.ti-rfid.com</a>
OMAP Mobile Processors	<a href="http://www.ti.com/omap">www.ti.com/omap</a>
Wireless Connectivity	<a href="http://www.ti.com/wirelessconnectivity">www.ti.com/wirelessconnectivity</a>

### Applications

Automotive and Transportation	<a href="http://www.ti.com/automotive">www.ti.com/automotive</a>
Communications and Telecom	<a href="http://www.ti.com/communications">www.ti.com/communications</a>
Computers and Peripherals	<a href="http://www.ti.com/computers">www.ti.com/computers</a>
Consumer Electronics	<a href="http://www.ti.com/consumer-apps">www.ti.com/consumer-apps</a>
Energy and Lighting	<a href="http://www.ti.com/energy">www.ti.com/energy</a>
Industrial	<a href="http://www.ti.com/industrial">www.ti.com/industrial</a>
Medical	<a href="http://www.ti.com/medical">www.ti.com/medical</a>
Security	<a href="http://www.ti.com/security">www.ti.com/security</a>
Space, Avionics and Defense	<a href="http://www.ti.com/space-avionics-defense">www.ti.com/space-avionics-defense</a>
Video and Imaging	<a href="http://www.ti.com/video">www.ti.com/video</a>

TI E2E Community Home Page

[e2e.ti.com](http://e2e.ti.com)

Mailing Address: Texas Instruments, Post Office Box 655303, Dallas, Texas 75265  
Copyright © 2012, Texas Instruments Incorporated